

Power Wheel® Service Manual

Model 9 Double Reduction Wheel Drives

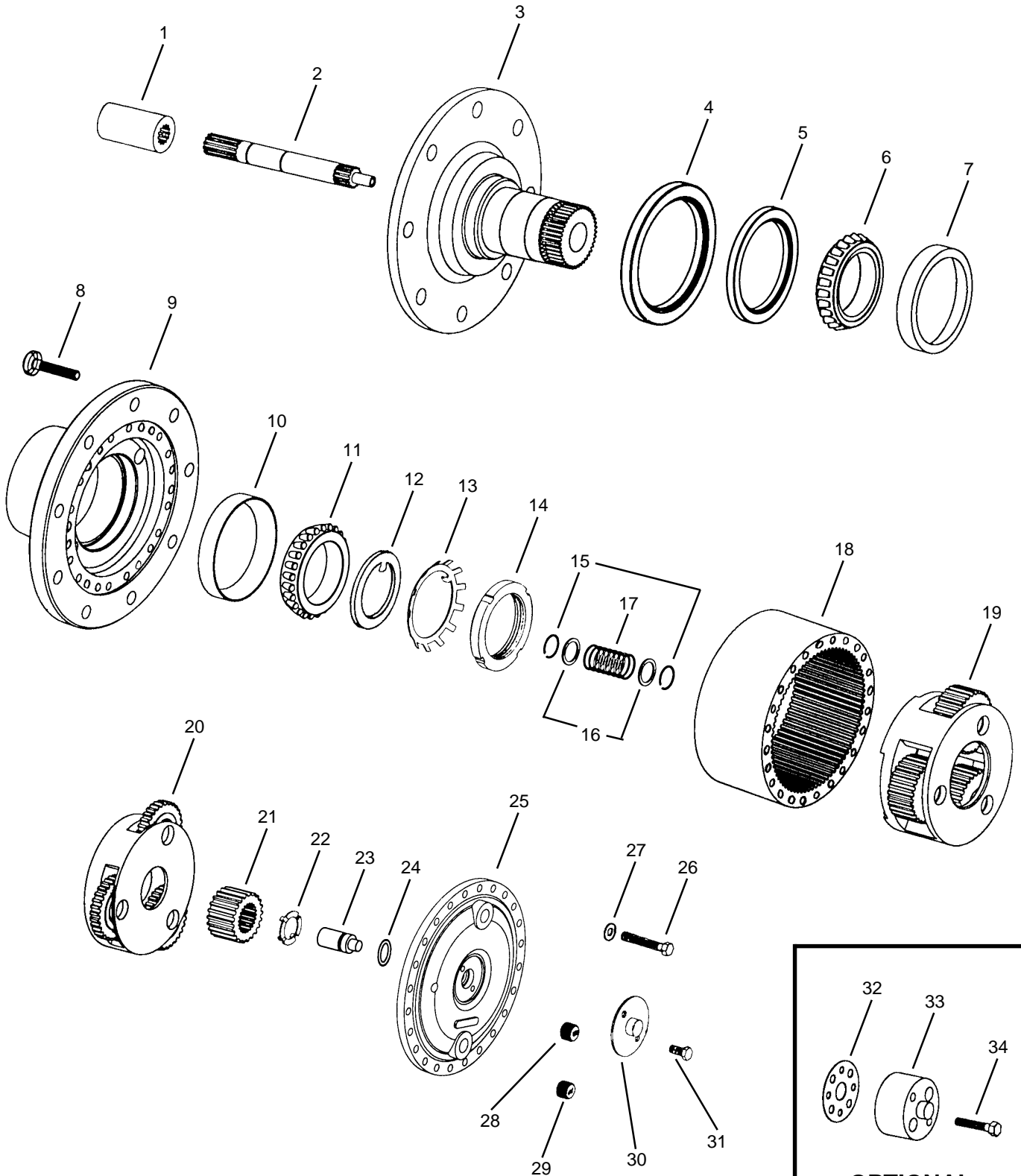

PHONE: (219) 925-3200
FAX: (219) 925-4725



OPTIONAL

IDENTIFICATION

IMPORTANT: All Power Wheel units and kits are shipped with a nameplate that includes the Auburn Gear part number and order code as shown.

Example:



In addition to the nameplate, Power Wheel drives are stamped with an identification number which appears on the cover or hub flange as shown.

Example: **6000236-A-4-9**

When ordering parts, the information included on the nameplate or the stamped identification number is necessary to accurately identify the drive and obtain the correct replacement parts. Once this information has been obtained, contact Auburn Gear for the appropriate parts list.

DISASSEMBLY OF POWER WHEEL

STEP 1

Slide the coupling (1) from splines on input shaft (2).

STEP 2

Position the assembly upright on face of spindle (3).

STEP 3

Remove the disengage cover (30) if necessary.

STEP 4

Remove twentyfour bolts (26) and flat washers (27) and the large cover (25) from the unit. The thrust washer (22) and the disengage plunger (23) usually remain attached to the large cover (25) when it is removed. Remove thrust washer (22), disengage plunger (23) and "O" ring (24) from the large cover (25).

STEP 5

Remove primary sun gear (21) from end of input shaft (2).

STEP 6

Remove the primary carrier assembly (20).

STEP 7

Remove the secondary carrier assembly (19). It may be necessary to remove the ring gear (18) first, if difficulty is encountered in removing the carrier.

STEP 8

Remove the input shaft (2) from spindle (3). Remove the retaining rings (15), washers (16), and disengage spring (17) from input shaft (2) only if replace-

ment is required.

STEP 9

If not previously removed (see step 7) remove ring gear (18) from hub (9). It may be necessary to strike ring gear (18) with a rubber mallet to loosen from hub (9).

STEP 10

One tab of lock washer (13) will be engaged in the slot of bearing nut (14); bend back to release. Remove the bearing nut (14), lock washer (13) and thrust washer (12). **Note:** A special locknut wrench, 593RR, is required for the removal of the bearing locknut. Contact Auburn Gear for procurement of wrench and other service tools.

STEP 11

Bolt spindle drive tool, 598FF, to hub (9). Drive spindle (3) from hub (9) by turning bolt in center of spindle drive tool. Care should be taken to avoid damaging splines and threads on spindle. **Note:** Bearing cone (11) has been designed with a press fit with respect to spindle (3). Considerable force will be required to remove cone from spindle.

STEP 12

Remove the boot seal (4) and oil seal (5) and bearing cones (6 & 11) from hub (9). Inspect bearing cups (7 & 10) in position and remove only if replacement is required.

ASSEMBLY OF POWER WHEEL

STEP 1

Press new bearing cups (7 & 10) in each side of the hub (9). It is recommended that bearing cups (7 & 10) and cones (6 & 11) be replaced in sets.

STEP 2

Assemble bearing cone (6) into cup (7) at seal end of hub (9) and press a new seal (5) into hub (9). Install boot seal (4) on hub (9) if unit is so equipped.

STEP 3

Position spindle (3) upright on bench. Lubricate lips of seals (4) and (5) and lower hub (9) onto spindle (3). Hub (9) should be centered as it is lowered over spindle (3) to prevent seal damage.

STEP 4

Assemble bearing cone (11) over spindle (3). Press bearing cone (11) over spindle bearing journal using press and cylindrical bearing cone driver 598F. Press bearing cone (11) down until rollers just touch cup (10). Take care to avoid pressing cone (11) too far. **Note:** If a press is not available, place tool 598F over splined end of spindle (3) on the edge of bearing cone (11) and drive into place with hammer or mallet. If this method is used, care must be taken to avoid damage to bearing cone and spindle.

STEP 5

Install thrust washer (12) and bearing nut (14). **DO NOT install lock washer (13) at this time.**

STEP 6

Place spindle drive tool, 598FF, over spindle (3) and bolt or pin to hub (9).

STEP 7

Check initial rolling torque by installing a lb.-in. torque wrench (arm or dial type) on center nut of spindle drive tool and turning hub (9) slowly and steadily with the torque wrench. Note mean torque. An initial bearing torque of greater than 52 lb.-in. with boot seal installed or 48 lb.-in. without boot seal means that the cone (11) was pressed on too tightly in step 4. In this case, back off bearing cone (11) by pressing spindle (3) out of cone (11) until initial preload is relieved. See step 11 of disassembly procedure.

STEP 8

Torque bearing nut (14) with bearing nut wrench 593RR until a bearing rolling torque of 44 - 52 lb.-in., with a boot seal installed, or 40 - 48 lb.-in., without a boot seal, is reached. This may require several trials of pressing the cone (11) by torquing the nut (14) and then checking the rolling torque. Rotate hub (9) by hand as nut is being tightened in order to seat bearings. **Note:** Up to 250 lb.-ft. of torque may have to be applied to bearing nut (14) in order to press cone (11) into position.

STEP 9

Remove bearing nut (14) and install lock washer (13). Replace bearing nut (14).

STEP 10

Re-torque bearing nut (14) to 65 - 75 lb.-ft. (88 - 100 Nm).

STEP 11

Secure bearing nut (14) by bending a lock washer (13) tab into one of four bearing nut slots. If no tab aligns with a slot, the nut may be tightened until one of the slots aligns with a lock washer tab.

STEP 12

Assemble a washer (16), spring (17), a second washer (16), and a retaining ring (15) in the middle grooves of input shaft (2). Install a second retaining ring (15) in groove near small end of input shaft (2).

STEP 13

Assemble the splined end of the input shaft (2) down into spindle (3).

STEP 14

Assemble the secondary carrier assembly (19) to spindle (3) at splines.

STEP 15

Clean mating surfaces and apply a bead of silicone sealant to face of hub (9) that mates with ring gear (18). See instructions on sealant package. Assemble ring gear (18) to hub (9) being careful to align bolt holes.

STEP 16

Assemble the primary carrier assembly (20) into the ring gear (18). It will be necessary to rotate carrier to align secondary sun gear (part of primary carrier assembly (20)) with planet gear teeth in secondary carrier assembly (19).

Assemble primary sun gear (21) over input shaft (2). Rotate primary sun gear (21) to align input shaft (2) to gear splines and gear teeth in primary carrier assembly (20).

STEP 17

Lubricate "O" ring (24) and assemble in groove inside cover hole, push disengage plunger (23) into cover (25) with pointed end facing inside of unit.

STEP 18

Assemble the thrust washer (22) with tangs engaged with cover (25). **NOTE:** A small amount of grease applied to the back side of thrust washer (22) will hold washer in place. Apply a bead of silicone sealant to end of face of ring gear (18). Assemble cover (25) aligning holes of cover and ring gear. Assemble the twentyfour 3/8-16 x 6-1/2 inch grade 8 bolts (26) and flat washers (27). Torque bolts to 45 - 50 lb.-ft. (61 - 67 Nm).

STEP 19

Assemble the disengage cover (30) with dimpled center protruding out if wheel is to be used to drive the vehicle. Assemble and torque the two 5/16-18 x 1/2 inch bolts (31). Torque bolts to 10 - 20 lb.-ft. (13 - 27 Nm).

STEP 20

Invert the Power Wheel assembly and assemble the coupling (1), with counterbore out, to the input shaft (2).

STEP 21

After motor is assembled to drive or drive is sealed at spindle, fill with lubricant to proper level and replace all plugs.

NOTE: When installing a hydraulic motor to the Power Wheel drive it is necessary to place an "O" ring or gasket (not supplied by Auburn Gear) between the motor and the planetary drive. "O" ring sizes: SAE A 2-042, SAE B 2-155, SAE C 2-159.

CARRIER ASSEMBLIES

It is recommended that the primary and secondary carrier assemblies (19 & 20) be serviced in their entirety to protect the integrity of the Power Wheel drive.

LUBRICATION RECOMMENDATIONS

IMPORTANT: POWER WHEEL PLANETARY DRIVES ARE SHIPPED WITHOUT LUBRICANT AND MUST BE FILLED TO THE PROPER LEVEL PRIOR TO START UP.

Observe lubrication recommendations given by the original equipment manufacturer. When specific recommendations are not available, use mild extreme pressure lubricant API-GL-5, No. 80 or 90 when filling the Power Wheel under normal temperature ranges between 0 - 120°F (-18 to 49°C). Power Wheel is to be half full of oil when unit is mounted level and horizontal. Use drain and fill plugs located in cover and ring gear. Oil is to be changed after first 50 hours of operation with subsequent changes every 1000 hours or yearly, which ever comes first. If unit is to be operated vertically, if ambient conditions are outside the specified range, or if the oil temperature exceeds 200°F (93°C) contact Auburn Gear for oil and level recommendations.

TOWING VEHICLE

CAUTION: The Power Wheel will not normally be damaged by towing; however, the hydraulic drive components may be damaged unless the Power Wheel is disengaged from the drive motor. Road speeds in excess of 25 MPH should be avoided unless clearly specified to be permissible by the equipment manufacturer.

TO DISENGAGE POWER WHEEL

CAUTION: For units equipped with the standard spring disconnect, assemble the disengage cover (30) with the dimpled center protruding in ward. For units equipped with the optional quick disconnect, push in center plunger of disconnect.

STORAGE

A protective film is applied to the Power Wheel at the factory to prevent rust during shipment. Additional protection may be required if the Power Wheel is to be stored for an extended period of time.

SEALING COMPOUND

Silastic RTV732 sealer and General Electric Silimate RTV No. 1473 or RTV No. 1503 are currently recommended for sealing gasket surfaces. Sealant should be applied in a continuous bead, which should be centered on the surface to be sealed but should move to the inside of the hole at each bolt hole location. For service requirements order Auburn Gear part number 604101.

SPECIFICATIONS

Maximum intermittent output torque	130,000 lb. in. (14,690 Nm)
Maximum input speed	5,000 RPM
Oil capacity	57 oz (1,685 ml)

ITEM NO.	DESCRIPTION*	NO. USED IN ASS'Y.	ITEM NO.	DESCRIPTION*	NO. USED IN ASS'Y.
1	Coupling	1	18	Ring Gear	1
2	Input Shaft	1	19	Secondary Carrier Assembly	1
3	Spindle	1	20	Primary Carrier Assembly	1
4	Boot Seal 604403	1	21	Primary Sun Gear	1
5	Oil Seal 604409	1	22	Thrust Washer	1
6	Bearing Cone 14-00-133-007	1	23	Disengage Plunger	1
7	Bearing Cup 14-00-133-006	1	24	"O" Ring 614101	1
8	Wheel Bolt	8-10	25	Large Cover	1
9	Hub	1	26	Hex Head Bolt (Grade 8)	24
10	Bearing Cup 613314	1	27	Flat Washer	24
11	Bearing Cone 613315	1	28	Magnetic Plug 14-00-052-002	1
12	Thrust Washer 619320	1	29	Pipe Plug	1
13	Lock Washer 605003	1	30	Disengage Cover 14-02-039-005	1
14	Bearing Nut 614912	1	31	Hex Head Bolt 618305	2
15	Retaining Ring	2	32	Quick Disconnect Gasket	1
16	Washer	2	33	Quick Disconnect Assembly	1
17	Disengage Spring 615604	1	34	Hex Head Bolt	2

* Contact Auburn Gear with part number and order code of drive to obtain the appropriate parts list. Refer to parts list for the specific part numbers and quantities.

Model 9 Power Wheel® Service Kits

Part No.	Description	Included Items
593RR	Bearing Locknut Tool	Not Shown
598F	Bearing Cone Driver	Not Shown
598FF	Spindle/Shaft Drive Tool	Not Shown